

FS2-FP20 - SWIRL POT SETUP FOR TI PUMP

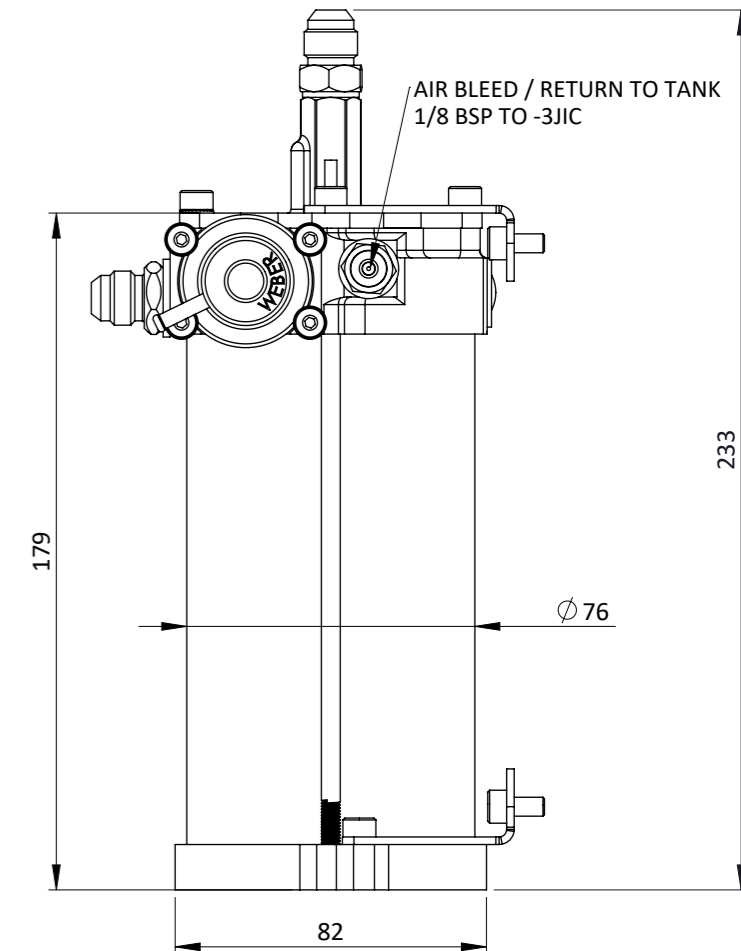

Engineered to win

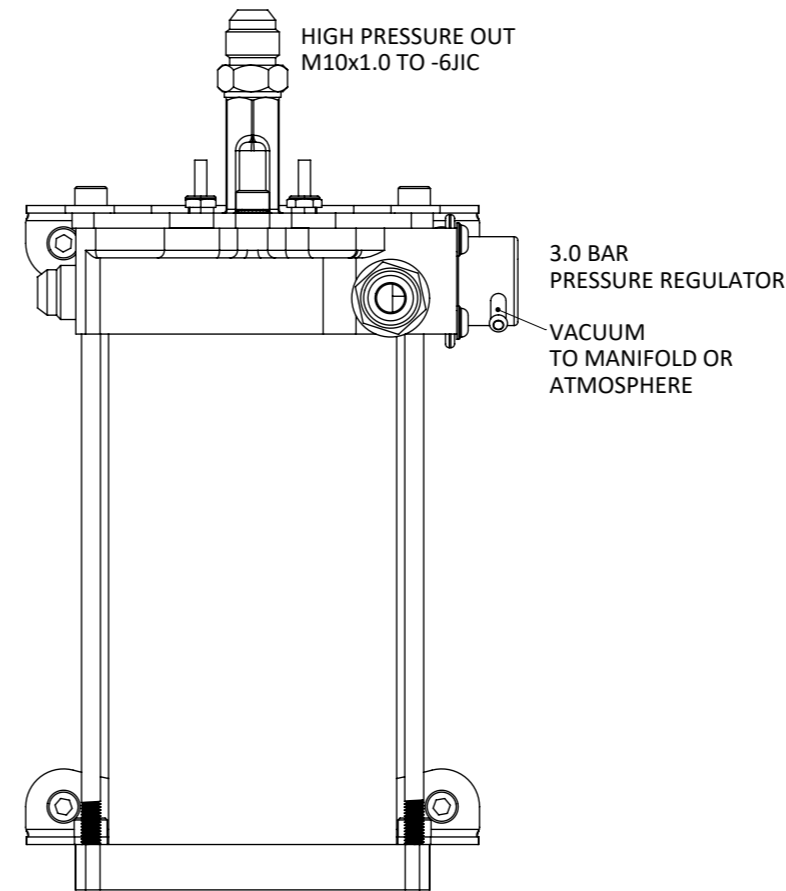
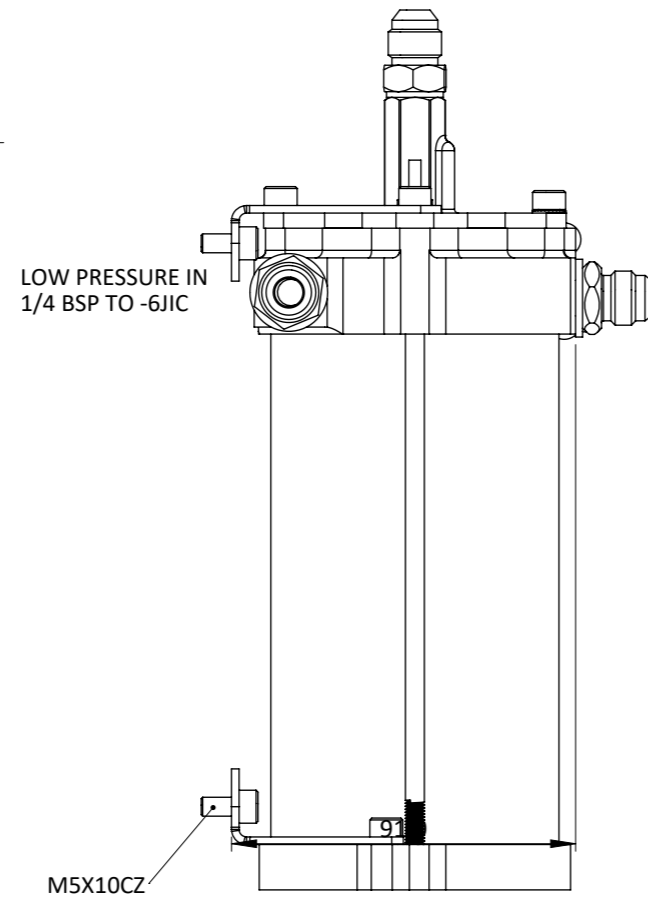
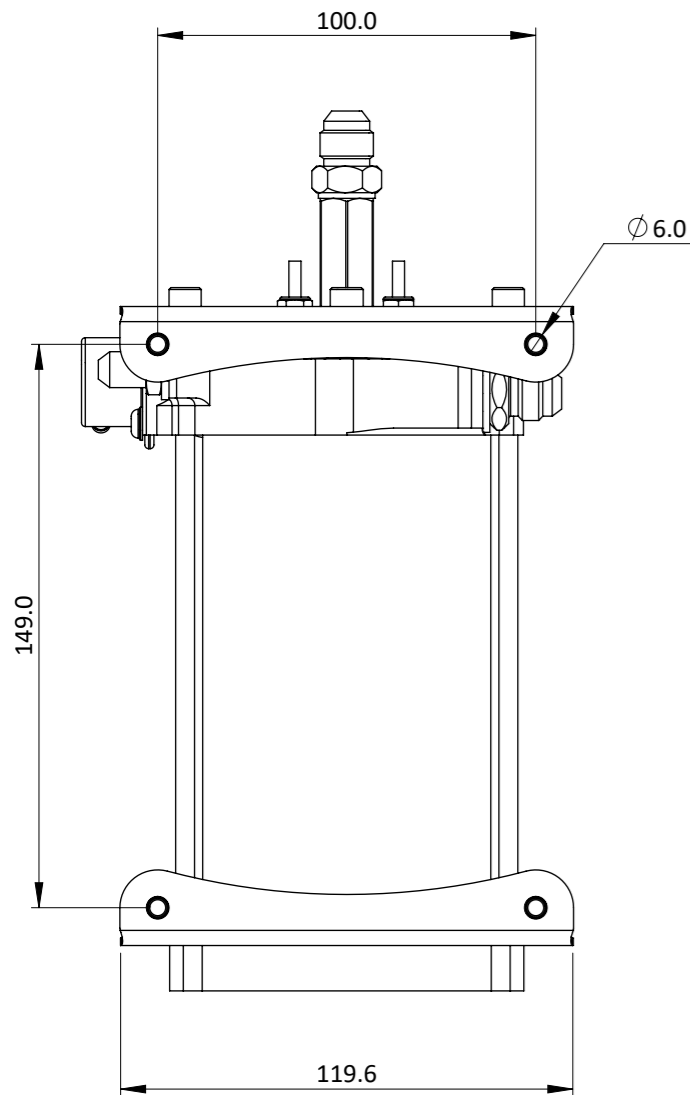
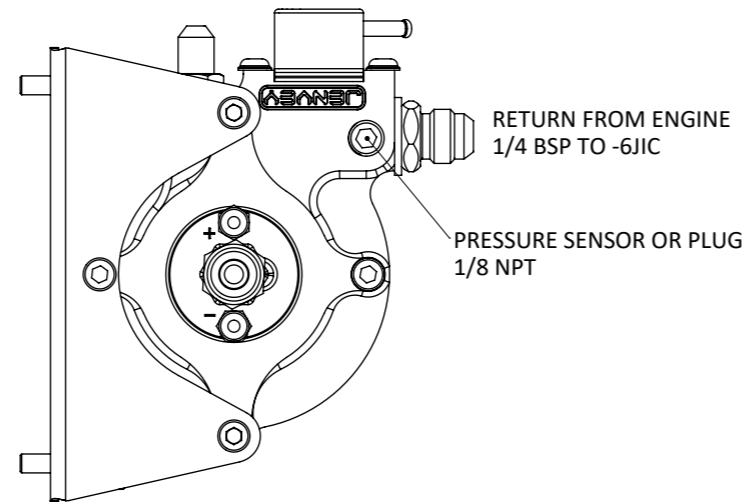
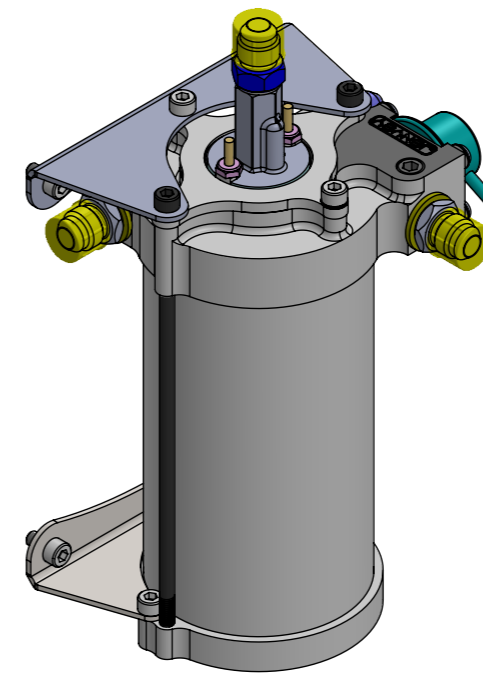

FUEL VOLUME: 490 ML
60 MICRON PRE-FILTER
TI AUTOMOTIVE INLINE HIGH PRESSURE FUEL PUMP
222 L/HOUR AT 5 BAR
3.0 BAR WEBER FUEL PRESSURE REGULATOR INCLUDED

**SWIRL POT MUST BE MOUNTED
WITHIN 5° OF VERTICAL**

Frame: 1 of 1

Version: 5

Tel 01746 768810

© JENVEY DYNAMICS LTD. 2015

Web WWW.JENVEY.CO.UK

